



# Multifrequency Pattern Generation Using Group-Symmetric Circuits

Joseph Neff, Visarath In, Brian Meadows, Christopher Obra,  
Antonio Palacios, and Ricardo Carretero-González

November 2006

Publication Number: CSRCR2006-11

Computational Science &  
Engineering Faculty and Students  
Research Articles

Database Powered by the  
Computational Science Research Center  
Computing Group

## COMPUTATIONAL SCIENCE & ENGINEERING



**SAN DIEGO STATE  
UNIVERSITY**

Computational Science Research Center  
College of Sciences  
5500 Campanile Drive  
San Diego, CA 92182-1245  
(619) 594-3430



# Multifrequency Pattern Generation Using Group-Symmetric Circuits

Joseph Neff\*, Visarath In\*, Brian Meadows\*, Christopher Obra\*, Antonio Palacios†, and Ricardo Carretero-González†

\*Space and Naval Warfare Systems Center, Code 2363, 53560 Hull Street, San Diego, CA 92152-5001, USA

†Nonlinear Dynamical Systems Group, Department of Mathematics and Statistics, San Diego State University, San Diego, CA 92182, USA

**Abstract**— This paper explores the use of networked electronic circuits, which have symmetrical properties, for generating patterns with multiple frequencies. Using a simple bistable sub-circuit, connected in a network with a specific topology, the principal operating frequencies of the network are divided in to two groups, with one group oscillating at twice the frequency of the other group. Specifically, group-theoretic arguments are used to dictate the particular coupling topology between the unit bi-stable cell. These concepts are demonstrated in a simple and compact CMOS circuit. The circuit is minimalistic, and demonstrates how simple and robust circuits can be used to generate useful patterns.

**Index Terms**— multifrequency, symmetry, group, pattern.

## I. INTRODUCTION

Recently multifrequency patterns have been observed in electronic circuits [1]. These systems have also been explored in great theoretical detail [2]. As a body of work, these examples, which demonstrate the use of symmetry based arguments for the construction of pattern generation systems, represent a significant move towards creating high-level biologically inspired systems. Already these concepts have been used to create centralized pattern generators, which mimic those supposed to be found in biological systems [3]. As a unifying concept throughout these works, symmetry is used to create robust networks of nonlinear cells in order to generate a single or set of needed patterns. The networks are robust in the sense that even though they must meet the needed symmetry requirements, the specification for the individual unit cell is less specific. In fact, the actual system is robust with regard to the choice of the individual cell. Similar to those results presented in [1], this paper presents a simple CMOS circuit that demonstrates multifrequency pattern generation. These experiments deviate from the previous work, not just by presenting a simple single IC solution, but also by adopting a slightly different mechanism for the bistable nature of the unit cell. Additionally, a nonlinear coupling network is employed.

In this work, we show that multifrequency patterns can be realized in a CMOS circuit consisting of two coupled arrays with three oscillators in each array. We demonstrate a particular pattern where in-phase oscillators are induced to oscillate at  $N$  times the frequency of the opposite array. Central to this work is the use of symmetry in a systematic way. In particular we adopt the group theoretical approach developed by Golubitsky and co-workers [4], [5], [6] to study symmetric

systems. Such an approach is model independent because the results are dictated exclusively by the symmetry of the system regardless of the nature of the oscillators. In this work, we also use symmetry in a systematic way to identify certain multifrequency patterns that, otherwise, would be difficult to find through the standard theory of synchronization or frequency entrainment [7].

## II. MULTIFREQUENCY PATTERN WITH $\mathbf{Z}_N \times \mathbf{S}^1$ SYMMETRY

To study the collective behavior of the network, we use  $X(t) = (X_1(t), \dots, X_N(t))$  to represent the state of one array and  $Y(t) = (Y_1(t), \dots, Y_N(t))$  to denote the state of the second array. Thus, at any given time  $t$ , a spatio-temporal pattern generated by the network can be described by  $P(t) = (X(t), Y(t))$ . Let us assume that this pattern is a periodic solution of period  $T$  with the following characteristics. On one side of the network, for instance, the  $X$ -array, the oscillators form a *traveling wave* (TW), i.e., same wave form  $X_0$  shifted (delayed) by a constant time lag  $\phi = T/N$ :  $X_k(t) = X_0(t + (k-1)\phi)$ ,  $k = 1, \dots, N$ . On the opposite side, the oscillators are assumed to be *in-phase* (IP) with identical wave form  $Y_0$ , i.e., a synchronous state:  $Y_k(t) = Y_0(t)$ ,  $k = 1, \dots, N$ . Now assume that  $P(t)$  has spatio-temporal symmetry described by the cyclic group  $\mathbf{Z}_N$ , i.e, the group of cyclic permutations of  $N$  objects generated by  $(1, 2, \dots, N) \mapsto (N, 1, \dots, N-1)$ , and by the group  $\mathbf{S}^1$  of temporal shifts. Together,  $\mathbf{Z}_N \times \mathbf{S}^1$  acts on  $P(t)$  as follows. First,  $\mathbf{Z}_N$  cyclically permutes the oscillators of both arrays:

$$\begin{aligned} \mathbf{Z}_N \cdot X_{TW}(t) &= \{X_N(t + (N-1)\phi), X_1(t), \dots, \\ &X_{N-1}(t + (N-2)\phi)\}, \\ \mathbf{Z}_N \cdot Y_{IP}(t) &= \{Y_N(t), Y_1(t), \dots, Y_{N-1}(t)\}. \end{aligned}$$

Then  $\mathbf{S}^1$  shifts time by  $\phi$  so that

$$\begin{aligned} \mathbf{Z}_N \times \mathbf{S}^1 \cdot X_{TW}(t) &= \{X_N(t), X_1(t + \phi), \dots, \\ &X_{N-1}(t + (N-1)\phi)\}, \\ \mathbf{Z}_N \times \mathbf{S}^1 \cdot Y_{IP}(t) &= \{Y_N(t + \phi), Y_1(t + \phi), \dots, \\ &Y_{N-1}(t + \phi)\}. \end{aligned}$$

Since the oscillators are identical, we get

$$\begin{aligned} \mathbf{Z}_N \times \mathbf{S}^1 \cdot X_{TW}(t) &= X_{TW}(t), \\ \mathbf{Z}_N \times \mathbf{S}^1 \cdot Y_{IP}(t) &= Y_{IP}(t + \phi). \end{aligned}$$

It follows that in order for  $Y_{IP}(t)$  to have  $\mathbf{Z}_N \times \mathbf{S}^1$  symmetry the in-phase oscillators must oscillate at  $N$  times the frequency of the oscillations of the traveling wave. The same conclusion is reached if the roles of the  $X$  and  $Y$  arrays are interchanged.

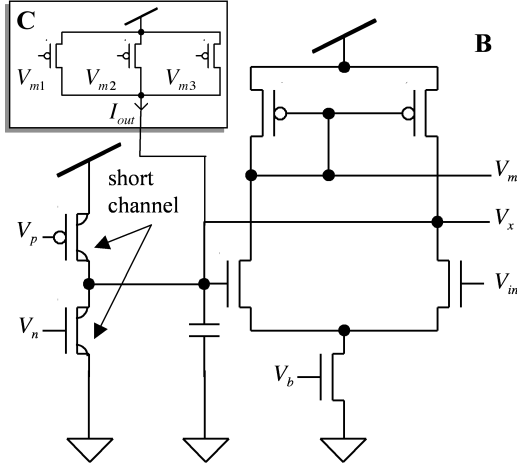

Fig. 1. A simple bistable circuit (labeled **B**) is constructed of two short channel transistors and an ordinary transconductance amplifier. The short channel transistors provide the 'linear' response while the OTA provides a nonlinear response resulting in the circuit's bistability. A coupling circuit (labeled **C**) is also shown.

### III. BISTABLE CIRCUIT

In these experiments a simple bistable circuit is adopted as the unit cell. The bistable circuit is similar to the overdamped Duffing oscillator adopted in [1]. The circuit, shown in Fig. 1, consists of a simple ordinary transconductance amplifier (OTA), an implicit or explicit capacitor, and two short channel transistors. In the figure, the state variable is represented as  $V_x$  and is a voltage.  $V_{in}$  represents the input signal and  $V_m$  is an output to the coupling circuit. In this system, the coupling circuits are simply current mirrors, resulting in only one additional transistor per coupling term. An example of three coupling inputs is shown in the inset labeled **C**. Without rigorous derivation we adopt a simple first-order differential equation for the single uncoupled circuit:

$$C\dot{V}_x = I_0 - I_l \frac{V_x}{V_e} + I_b \tanh\left(\frac{V_x - V_{in}}{2U_t}\right) \quad (1)$$

The equation qualitatively describes the nature of the circuit. In (1) the constant current  $I_0$  and linear response  $I_l \frac{V_x}{V_e}$  result from the drain-induced barrier loading effect of the short channel transistors. In (1)  $V_e$  is known as the Early voltage [8]. The OTA provides the nonlinear  $\tanh$  response. A simple equation for the nonlinear double-well potential governing (1) can be found, as well as conditions on stability as a function of the accessible bias parameters  $V_p, V_n, V_b$ . In previous work this type of potential function has been referred to as a 'soft' potential, and has been explored in the context of other pattern

forming systems [9]. Qualitatively, for large enough input signals at  $V_{in}$ , the circuit will exhibit hysteresis and the output will switch between two stable states that are determined by the input signal and the three bias parameters.

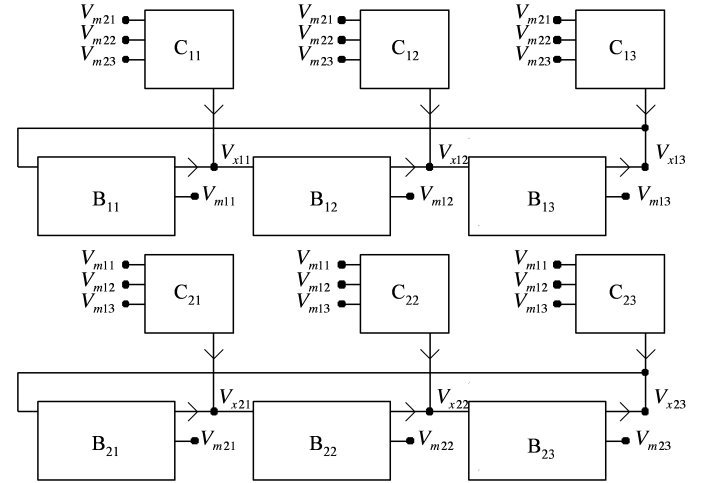

Fig. 2. A six-cell multifrequency generating network. Each bistable circuit is labeled **B** with the associated coupling circuit labeled **C**. The actual circuits are given in Figure 1. The system consists of two arrays, each with three unidirectionally coupled cells arranged in a ring. This coupling topology favors the traveling wave patterns described above. In addition to the unidirectional coupling, each cell in each array receives a coupling input from all the cells in the opposite array. It is the symmetries within this coupling topology that result in the in-phase and traveling wave multifrequency solutions.

### IV. NETWORK

A six-cell multifrequency generating system is given in Fig. 2. Each bistable circuit is labeled **B** with the associated coupling circuit labeled **C**. The actual circuits are given in Fig. 1. The system consists of two arrays, each with three unidirectionally coupled cells arranged in a ring. The top ring is constructed by connecting the output variable  $V_{x1,i}$  to the next cell input  $V_{in1,i+1}$ . The ring is completed by connecting the last output  $V_{x1,3}$  to the first cell input  $V_{in1,1}$ . The bottom array is constructed identically to the top. This coupling topology favors the traveling wave patterns described in section II. In addition to the unidirectional coupling, the two arrays are also coupled to each other. Since each cell in one array is coupled to the three cells in the opposite array, only three additional transistors are required per cell. These coupling transistors are shown in the inset labeled **C** in the inset of Fig. 1. When operating the array, all the cell bias voltages are set the same. Designs for six-cell and ten-cell arrays were fabricated using the TSMC 0.35 $\mu$ m process through the MOSIS foundry system.

### V. PATTERNS

Spice simulations are used to demonstrate multifrequency patterns using the simple networked circuits presented in Fig. 1 and Fig. 2. For our simulations, a standard OTA design was used and very little effort was made to optimize the design for a particular performance. Transistors were simulated using the BSIM3 model along with model parameters provided

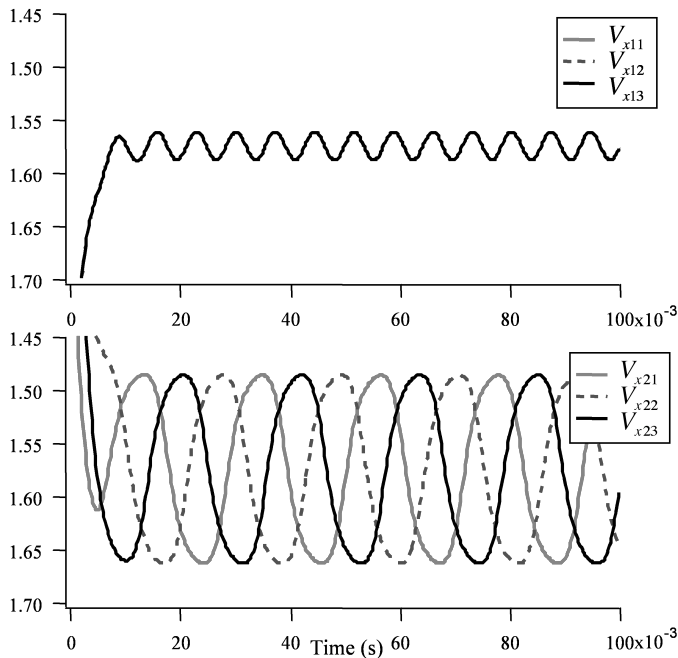

Fig. 3. Simulation results of a six-cell multifrequency generating network. The top and bottom plots are the time-series results for the  $V_{x1,i}$  and  $V_{x2,i}$  variables respectively. The figure shows the bottom array operating with a traveling wave solution, with each variable oscillating at a frequency, while the other array operates with an in-phase solution oscillating at a frequency of  $N$ .

by MOSIS. Fig. 3 shows simulation results of a six-cell multifrequency generating network. The top and bottom plots are the time-series results for the  $V_{x1,i}$  and  $V_{x2,i}$  variables respectively. The figure shows the bottom array operating with a traveling wave solution, with each variable oscillating at a frequency  $\omega$ , while the top array operates with an in-phase solution oscillating at a frequency of  $N\omega$ . These solutions are predicted by the group theoretic approach given in section II. To obtain these results the  $V_n$  and  $V_p$  are chosen so that the short channel transistors operate just above threshold and the OTA is operated below threshold.

For these same parameter settings an alternate pattern is also possible where both arrays oscillate with an out of phase solution, as shown in Fig. 4. The significant result here is that a single network system is capable of generating differing patterns, even with the same parameter settings. In nonlinear systems the coexistence of multiple solutions is not uncommon. In fact, the group theoretic approach is a convenient method for predicting what patterns are possible solutions considering a networked system that possess symmetries such as ours. However, the approach does not predict the stability of the solution given a particular parameter set. In these experiments, the two patterns shown in Fig. 3 and Fig. 4 appear to be stable. The patterns themselves are selected by preparing the initial conditions of the system at startup.

## VI. SUMMARY

To summarize, using symmetry-based arguments, we have shown that multifrequency patterns occur in a simple CMOS circuit. In particular, a two-array network with  $N$  identically

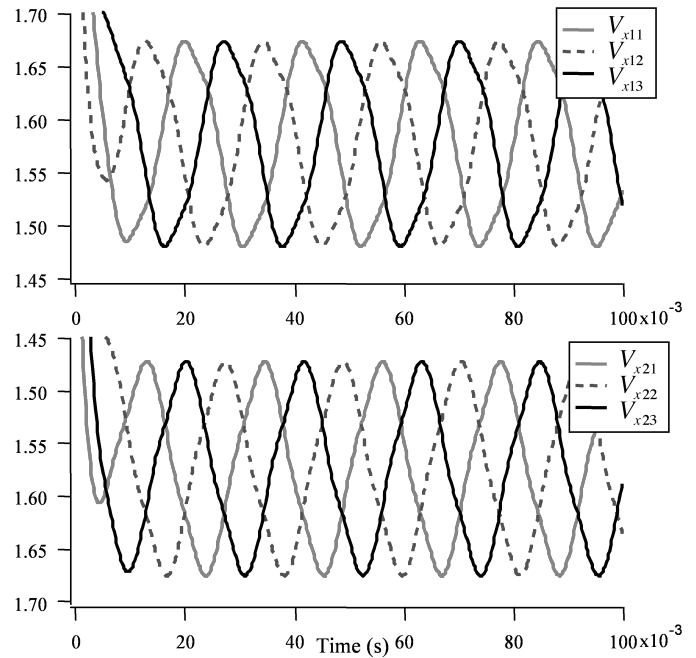

Fig. 4. Simulation results of a six-cell multifrequency generating network. The top and bottom plots are the time-series results for the  $V_{x1,i}$  and  $V_{x2,i}$  variables respectively. The figure shows both the bottom and top arrays operating with traveling wave solutions. This pattern is obtained from the same network with the same parameter settings that produced an alternate pattern shown in Fig. 3

coupled circuits per array was shown to have one array oscillate in a traveling wave pattern while the other array oscillates in phase but at  $N$  times the frequency of the traveling wave state. In principle, the number of elements in each array does not have to be identical; therefore, the frequency of the in-phase state can be changed based on the number of elements in the other array. Such a system might be used to create oscillations at arbitrary multiples of a unit frequency. An experimental example of a simple system was constructed CMOS circuits. Spice simulations, using the BSIM3 model for the transistors, confirm the existence of multifrequency behavior in the system. We also emphasize that the model independent feature of the symmetry methods used in this work imply that our results are valid for a general class of coupled oscillators regardless of the nature of the intrinsic dynamics of each unit cell. Two coexisting patterns were demonstrated with one network using identical; system parameters but differing initial conditions.

## ACKNOWLEDGMENT

The authors would like to thank the ONR In-house Laboratory Independent Research program for funding portions of this project.

## REFERENCES

- [1] V. In, A. Kho, J. Neff, A. Palacios, P. Longhini, and B. Meadows. *Phys. Rev. Lett.* **91** (2003) 244101.
- [2] A. Palacios, R. Gonzalez, P. Longhini, N. Renz, V. In, A. Kho, J. Neff, B. Meadows, and A. Bulsara. *Phys. Rev. E.* **72** (2005) 045102.
- [3] To be published.

- [4] M. Golubitsky and I. Stewart. In: *Geometry, Mechanics, and Dynamics*, (P. Newton, P. Holmes, and A. Weinstein, eds.) Springer, New York, (2002) 243.
- [5] M. Golubitsky, I. Stewart. In: *Pattern Formation in Continuous and Coupled Systems*, (M. Golubitsky, D. Luss and S.H. Strogatz, eds.) IMA Volumes in Mathematics and its Applications **115**, Springer, New York, (1999) 65–82.
- [6] M. Golubitsky, I.N. Stewart, and D.G. Schaeffer. *Singularities and Groups in Bifurcation Theory: Vol. II*. Appl. Math. Sci. **69**, Springer-Verlag, New York, 1988.
- [7] A. Pikovsky, N. Rosenblum, and J. Kuzh. *Synchronization. A Universal Concept in Nonlinear Sciences* Cambridge Nonlinear Sciences Series **12**, Cambridge University Press, Cambridge UK, 2001.
- [8] C. Mead, N. *Analog VLSI and Neural Systems* Cambridge Nonlinear Sciences Series **12**, Addison-Wesley, Reading, MA, 1989.
- [9] V. In, A. Bulsara, A. Palacios, P. Longhini, A. Kho, and J. Neff *Phys. Rev. E*. **68** (2003) 045102.